

INSTALLATION & PRODUCT MANUAL

Danger: Silica Dust	3
1. INTRODUCTION	4
1.1. Purpose	4
1.2. Terminology	4
1.3. General Information	4
1.4. Limitations & Responsibilities of WK Marble & Granite & the Consumers	5
2. SAFETY PROCEDURES	6
2.1. Basic Guidelines	6
i) Safety Procedures	6
3. VARIOUS APPLICATIONS OF QUANTUM QUARTZ	7
3.1. Interior Applications	7
3.2. Exterior Applications	7
4. TECHNICAL SPECIFICATIONS	8
4.1. Quantum Quartz Specifications	8
4.2. Quantum Quartz Colour, Surface Finish & Pattern	8
4.3. Quantum Quartz Colour Consistency & Tonal Characteristics	8
4.3.1 Variation	8
4.3.2 Lamination Strips & Orientation	9
4.3.3 Usable Area	10
4.4. Quantum Quartz Technical Characteristics	11
5. QUANTUM QUARTZ HYGIENIC CHARACTERISTICS	13
5.1. Surface Flammability & Smoke Development	13
6. GENERAL INSTRUCTIONS TO CUSTOMERS	14
6.1. General Instructions to Installers	14
6.2. Product Identification	14
6.3. Chemicals to Avoid	14

7.	DESIGN & INSTALLATION GUIDE	15
7.1.	Kitchen/Vanity Cabinets	15
7.2.	Installation of Benchtops	15
i)	Complete Perimeter Substrate Support	15
ii)	Complete Full Substrate Support	16
7.3.	Planning & Installation of Tops with Joints & Cut-outs	16
7.4.	Installing Dishwashers	19
7.5.	Overhang & Supporting Brackets	19
7.6.	Installation of Splashback	21
7.7.	Cladding Walls	21
7.8.	Installation of Tiles	21
7.9.	Installation of Kitchen Sinks & Cooktops	22
7.10.	Installation of Return Side Panel	22
7.11.	Edge Profile Details	23
7.12.	Viewing and inspecting distances	24
8.	MATERIAL SAEFTY DATA SHEET	25
9.	10 YEAR LIMITED WARRANTY	31
10.	CARE & MAINTENANCE	32



DANGER: SILICA DUST

Exposure to respirable crystalline
silica dust can cause silicosis or cancer

The finished product poses no health hazard



NO UNCONTROLLED DRY CUTTING
WEAR RESPIRATORY PROTECTIVE EQUIPMENT
AND APPROPRIATE PPE

For complete details on safe cutting
refer to wk.com.au/safecutting or aesig.com.au

IMPORTANT INFORMATION FOR STONE FABRICATORS

Danger: Silica Dust

Quantum Quartz and **Quantum Six+** and **natural stone** all contain crystalline silica. This material is known to cause cancer and have links to other diseases including silicosis, tuberculosis, pulmonary, kidney and autoimmune disease. These diseases can kill you. Following proper safety instructions eliminates the health risk. It is imperative that the proper safety measures contained in the Quantum Quartz and Quantum Six+ Installation and Product Manual be followed when fabricating all stone products including natural stone.

Fabricated material poses zero safety risk to anyone.

1. INTRODUCTION

1.1. Purpose

The purpose of this manual is to define the basic technical requirements, suggestions and guidelines related to the introduction of the product, design, its usage, installation and maintenance.

1.2. Terminology

The word Quantum Quartz[®] used in this document refers to any Engineered or manufactured stone in slab, tile or cut to size forms, marketed and sold by WK Marble & Granite Pty Ltd or its approved distributors or agents in Australia, New Zealand and Pacific Islands.

The word “the Customer” used in this document refers to any to any person, firm or company placing an order with WK Marble & Granite Pty Ltd or its approved distributors (“the Company”) for the purchase of any Quantum Quartz[®].

The word “Product manual” used in this document refers to the technical information, specification, design, fabrication, maintenance and other data relating to the use and application of Quantum Quartz[®].

1.3. General Information

Quantum Quartz[®] is a composite of natural minerals and rocks - mainly Quartz mineral bound with resin, pigments and other fillers. Quantum Quartz[®] is manufactured using the most advanced and latest technology from Breton stone machinery of Italy.

Quantum Quartz[®] engineered stone collection is sold all over Australia, New Zealand and Pacific Island countries by WK Marble & Granite Pty Ltd, the leader in the supply of natural stones and manufactured stones for the past 20 years. The Quantum Quartz[®] collection is unsurpassed in quality and variety by any other supplier of engineered stones in Australia.

Quantum Quartz[®] can be used in a variety of domestic and commercial interior applications including kitchen and vanity tops, splashbacks, wall cladding, stairs, furniture, lift walls, food service counters etc.

Quantum Quartz[®] is manufactured using the world renowned Breton Stone technology (Breton spa of Italy). The quality of engineered stone will vary from brand to brand depending on the quality of resin and raw materials used in the manufacture of the stone. Quantum Quartz[®] has been manufactured using the quality raw materials as specified and recommended by Breton spa of Italy.

Quantum Quartz[®] is a high quality, non-porous product that is highly resistant to scratching, staining and water absorption. Quantum Quartz[®] requires minimum maintenance and the surface remains in immaculate condition for years.

1.4. Limitations & Responsibilities of WK Marble & Granite & the Consumer/s.

We have taken every care to provide information in this document; this information should be used as a guide in the design, installation and care of Quantum Quartz®. No warranty, however implied or expressed, is given in relation to the procedures outlined in this Product Manual except that is required by law.

WK Marble & Granite Pty Ltd. assumes that the designers, fabricators and installers using the Product, are familiar with all aspects outlined in this Product Manual and strictly adhere to the recommendations and specifications described in the manual for use with Quantum Quartz® only. Any deviation from the recommended guidelines may result in the products not performing as expected and may result in the warranty becoming null and void.

A word of caution for people who are using this Product Manual, though every care and precaution has been taken in the preparation of this document, The Company assumes no responsibility for errors and or omissions, or for the damages resulting from the use of information contained in this Product Manual. Under no circumstances the Company shall be liable for any loss of profit or any other loss or damage caused or alleged to have been caused either directly or indirectly as a result of any person solely relying upon any information contained in this Product manual.

The Company reserves the right to change or modify this Product Manual or its electronic version from time to time without notice, it is the responsibility of the Consumer/s to consult or contact their local Quantum Quartz® distributor for accessing the latest version or updates.

2. SAFETY PROCEDURES

Danger: Silica Dust

Quantum Quartz (and to a lesser extent natural stone) contain crystalline silica. This material is known to cause cancer and have links to other diseases including silicosis, tuberculosis, pulmonary, kidney and autoimmune disease. It is imperative that the proper safety measures contained in the Quantum Quartz Installation and Product Manual be followed when fabricating material.

2.1. *Basic Guidelines*

i) Safety Procedures:

We recommend that the stonemason always adhere to good stone working and safety work practices and abide by all the building codes and regulations. In order to prevent any accidents. We strongly recommend that the stonemason follow these simple safety procedures.

- Prior to commencing the job the consumer should read The Product Manual and The Safety Data Sheet. The instruction manuals of adhesives & manuals for operating the various tools.
- The Quantum Quartz®, Quantum Six+ & Natural Stone sheets should be handled with at least two people. When handling these sheets always use industrial protective gloves (AS/NZS 2161) and proper lifting devices and make sure that the lifting straps, lifting clamps and vacuum lifters are free from defects.
- Make sure that the work area is free of all debris and keep the work area clean and tidy.

- When cutting Quantum Quartz®, Quantum Six+ or Natural Stone always wear safety glasses (AS/NZS 1337) and earmuffs (AS/NZS 1269).

Quantum Quartz®, Quantum Six+ & Natural Stone contain silica and the powder (silica powder) when inhaled is injurious to your health. Always cut the stones using wet tools in well-ventilated areas. Respiratory half face reusable Particle Filter Dust Mask to AS/NZS 1715 and 1716 and WHSQ silica document standards should be worn when processing and fabricating all materials.

https://www.worksafe.qld.gov.au/__data/assets/pdf_file/0020/163541/protecting-workers-from-respirable-crystalline-silica-guide.pdf

- Quantum Quartz®, Quantum Six+ or Natural Stone should only be cut using wet tools to avoid inhalation of fine silica dust.
All efforts should be made to avoid cutting, polishing, grinding or drilling of Quantum Quartz®, Quantum Six+ or Natural Stone at the installation premises. If alterations are unavoidable, no uncontrolled dry cutting is allowed, refer to PN12472 (below link) for correct guidelines and details regarding controlled dry cutting procedures
https://www.worksafe.qld.gov.au/__data/assets/pdf_file/0005/172157/installing-stone-benchtops.pdf

We strongly recommend you consult with your local governing WorkSafe office for further details in your State.

WK Marble & Granite Pty Ltd will not be held responsible for any pollution either directly or indirectly resulting out of processing the stone.

- Waterproof protective apron should be worn when using machines/tools with water applications
- Always wear proper clothing and never wear loose clothing or loosely hanging jewels for safety reasons
- It is important to wear only steel capped rubber soled industrial safety boots (AS/NZS 2210) when working with Quantum Quartz®, Quantum Six+ or Natural Stone.

3. VARIOUS APPLICATIONS OF QUANTUM QUARTZ®

3.1. *Interior Applications*

Quantum Quartz® is ideal for use in interior applications such as kitchen benchtops, bathrooms - vanity tops, floors and walls, stairs, restaurants, hotels, hospitals, and laboratories and also wherever high quality, sanitary and maintenance-free bench tops are required. Their use is comparable to that of natural stone, with the following additional advantages:

The uniformity of colouring permits additional, coordinated applications

- Minimum wastage of material used due to consistent size of the slabs
- Natural defects such as veining, pores, cracks or fissures are eliminated
- Resistant to moderate heat temperatures for a short period of time
- Resistant to stains
- Resistant to acids, alkaline, chemicals and solvents
- Resistant to mildew and mould
- Immune to freezing and thawing

Quantum Quartz® when exposed to direct sunlight may result in colour change and warping, it is advisable to avoid direct sunlight over a prolonged period on the surfaces used in the above applications.

3.2. *Exterior Applications*

The company does not recommend Quantum Quartz® for use in exterior applications, as Quantum Quartz® when exposed to direct sunlight may result in colour change and warping.

4. TECHNICAL SPECIFICATIONS

Quantum Quartz® is a high quality solid surface product that is long lasting and is practically maintenance free. Quantum Quartz® has a carefully designed colour palette of products that can be used in a variety of domestic and commercial applications. Quantum Quartz®, however is not an ideal product for exterior use as exposure to direct sunlight for prolonged periods can result in colour changes or fading and warping.

4.1. *Quantum Quartz® Specifications*

Quantum Quartz® slabs sizes: 3040 x 1440mm and available in 20mm and 30mm. (not all colours available 30mm thickness). The thickness may vary by plus or minus 1.5mm
Slab flatness: up to 2mm over 1.4 metre when slab is fully supported in horizontal position.

3310 x 1660mm – Custom order only – minimum quantities apply.

4.2. *Quantum Quartz® colour, surface finish and pattern*

Quantum Quartz® manufacturing process is renowned worldwide and contains more than 93% of natural quartz, 7% combined bonding agent, special additives and pigments, making it an extremely hard wearing, practical and highly versatile surface.

Quantum Quartz® is the ultimate in stone technology and sophistication has a colour palette ranging from the subtle beige tones to the vibrant beauty of the luminescent Starlight Colours, which provide you the opportunity to perfect your individual style and decor.

Quantum Quartz® slabs and tiles are generally available in the gloss finish only.

4.3. *Quantum Quartz® colour consistency and tonal characteristics:*

4.3.1 *Variation*

Variation in colour may occur from batch to batch of Quantum Quartz® slabs and tiles due to the location from which the natural material is sourced. The composition of natural quartz and granite particles used in the products may sometimes produce minor irregularities such as crazing in the grains, blotches, spots, coloured particles. Such imperfections are generally accepted by the industry.

Quantum Quartz® is a non porous product; but very fine micro pores could be present within the product range and is unavoidable during manufacturing process. These micro pores are present in the raw materials as they are characteristics of the natural quartz & granite particles (agglomerate) which make up to 93% of the product.

The agglomerate will also vary to some degree in each slab & within each slab & therefore we do not recommend adjacent installation of opposite sides or ends of the slab.

i.e.

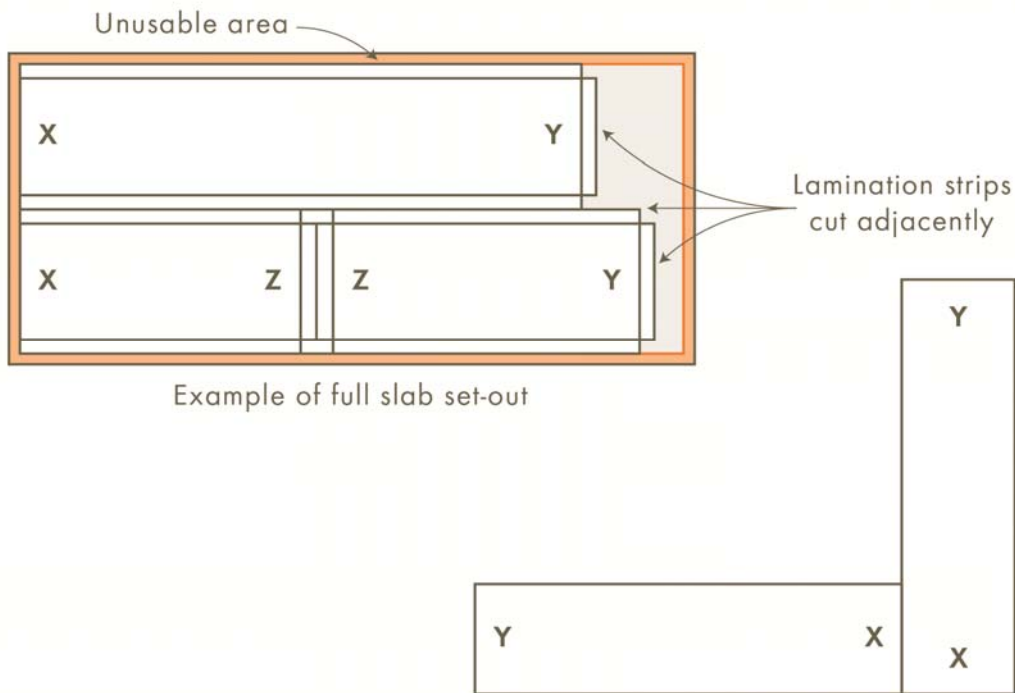

- Y edges should be kept together (labelling of slab edges prior to cutting is recommended)
- X edges should be kept together (labelling of slab edges prior to cutting is recommended)
- Z edges should be kept together (labelling of slab edges prior to cutting is recommended)

X to Y or X to Z or Y to Z adjacent butting may not always match with consistent colour or agglomerates.

X to X or Y to Y or Z to Z adjacent butting is preferred and recommended.

4.3.2 Lamination Strips & Orientation

It is highly recommended strips for use in lamination are cut from adjacent areas of the slab, preferably beside the cut edge of the benchtop pieces. This ensures the best match possible. Labelling of pieces is also recommended.

Orientation of the slabs is also recommended when using a second slab to complete a benchtop which is larger than a slab. Use the label markings on the reverse of the slab as a guide.

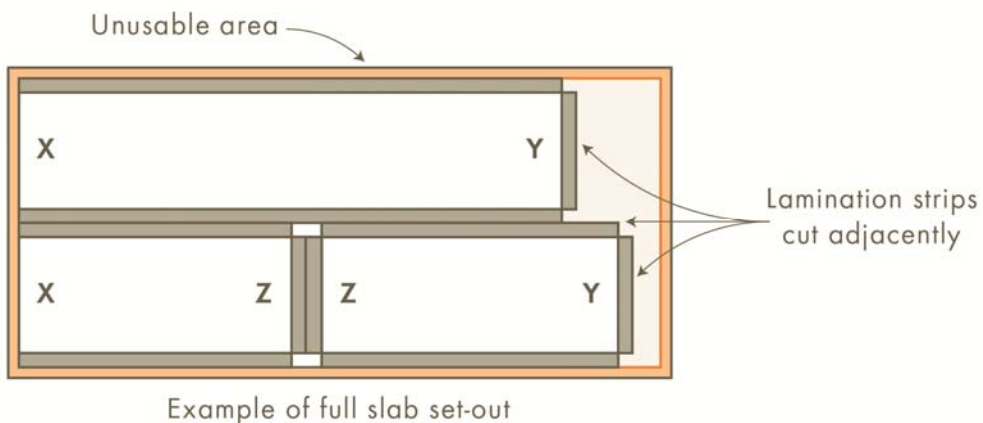

4.3.3 Usable Area

Quartz slabs are sold as 3040x1440mm nominal size & need to be trimmed & calibrated during the benchtop cutting process.

These are the manufacturing dimensions & due to production limitations cannot be considered as usable sizes. This nominal size protects the usable area from transportation, distribution or chipping damage which may occur during production &/or shipping.

Recommendations for usable size can be confirmed by Quantum Quartz or your fabricator, & may vary slightly from slab to slab.

The extreme perimeter of the slab should generally be trimmed during fabrication. If however a large piece is needed, close inspection is required to ensure the area is usable. Most slabs have a wedge like appearance which is the result of the production process; although on occasions it is trimmed during the production cycle. A close inspection is recommended to confirm whether the edge of the slab is usable prior to cutting as the unusable area varies slab to slab.



Table 1: ASTM

SPECIFICATION	TEST METHOD	RESULT
Water Absorption	ASTM C97	≤ 0.03%
Density	ASTM C97	2.2 – 2.4 gr/cm ³
Flexural Strength	ASTM C880	6,200 – 11,000 psi: 42.7 – 75.8 MPa
Dimension Stability	EN 14617-12	Class A
Electrical Stability	EN 14617-13	Volume Resistance (R _v) = 0.9 x 10 ¹⁴ Ω Volume Resistivity (ρ _v) = 4.9 x 10 ¹⁴ Ωm
Impact Resistance	ASTM D1709	27 lbs (122 N)
Compressive Strength	ASTM C170	22,000 – 28,000 psi
Abrasion	ASTM C1243	Volume of Chord: V=89 – 194mm ³
Freeze-Thaw Resistance	ASTM C1026	No defects after 15 freeze-thaw cycles
Mohs Hardness Scale	EN 101	6.0 – 7.0
Microbial Resistance	ASTM D6329	Ranking 3: Resistant to Mould Growth
Resistance to Chemical Acids	ASTM C560	No Affect
Slip Resistance - Honed 400	DIN 51130	R9 – R10
Slip Resistance - Polished	AS/NZS4586:2004 Appendix B	Z
	AS/NZS4586:2004 Appendix A	F
Determination of Resistance to Immersion in Boiling Water	AS 2924.2-7: 1998 (EQUI. TO ISO 4586.2-7: 1997)	Effect on surface (rating): 5 (no visible change)
Determination of Resistance to Dry Heat	AS 2924.2-8: 1998 (EQUI. TO ISO 4586.2-8: 1997)	Effect on surface (rating): 5 (no visible change)
Determination of Resistance to Staining (Procedure A)	AS 2924.2-15: 1998 (EQUI. TO ISO 4586.2-15: 1997)	Effect on surface (rating): 5 (no visible change)
Determination of Resistance to Thermal Shock	AS 2924.2-9: 1999 (EQUI. TO ISO 10545-9: 1994)	Specimens showing defects: Nil
Toxicity	Complies with the Standard 51 NSF/ANSI – Food equipment materials, solid surfaces for splash zone	
Suitability for use in Kitchen Benchtops	EMPFEHLUNG XII BGVV	Suitable

Note: The values quoted above for Quantum Quartz® are average range of values of the different Quartz products tested and should be considered as an indication only. The test results may vary depending on the colours and also the batches of the products.

Table 2: EN

SPECIFICATION	TEST METHOD	RESULT
Water Absorption	EN 14617-1	≤ 0.03%
Density	EN 14617-1	2.2 – 2.4 gr/cm ³
Flexural Strength	EN 14617-2	40 – 80 MPa
Dimension Stability	EN 14617-12	Class A
Electrical Stability	EN 14617-13	Volume Resistance (R _v) = 0.9 x 10 ¹⁴ Ω Volume Resistivity (ρ _v) = 4.9 x 10 ¹⁴ Ωm
Impact Resistance	EN 14617-9	4.0 – 10.0 J
Compressive Strength	EN 14617-15	154 – 196 MPa
Resistance to Deep Abrasion	EN 14617-4	Volume of Chord: V=89 – 194mm ³
Freeze-Thaw Resistance	EN 14617-5	No defects after 25 freeze-thaw cycles
Mohs Hardness Scale	EN 101	6.0 – 7.0
Microbial Resistance	ASTM D 6329	Ranking 3: Resistance to Mould Growth
Resistance to Chemical Acids	EN 14617-10	Class C ₄
Slip Resistance - Honed 400	DIN 51130	R9 – R10
Slip Resistance - Polished	AS/NZS4586:2004 Appendix B	Z
	AS/NZS4586:2004 Appendix A	F
Determination of Resistance to Immersion in Boiling Water	AS 2924.2-7: 1998 (EQUI. TO ISO 4586.2-7: 1997)	Effect on surface (rating): 5 (no visible change)
Determination of Resistance to Dry Heat	AS 2924.2-8: 1998 (EQUI. TO ISO 4586.2-8: 1997)	Effect on surface (rating): 5 (no visible change)
Determination of Resistance to Staining (Procedure A)	AS 2924.2-15: 1998 (EQUI. TO ISO 4586.2-15: 1997)	Effect on surface (rating): 5 (no visible change)
Determination of Resistance to Thermal Shock	AS 2924.2-9: 1999 (EQUI. TO ISO 10545-9: 1994)	Specimens showing defects: Nil
Slip Resistance - Polished	AS/NZS4586:2004 Appendix B	Z
	AS/NZS4586:2004 Appendix A	F
Determination of Resistance to Immersion in Boiling Water	AS 2924.2-7: 1998 (EQUI. TO ISO 4586.2-7: 1997)	Effect on surface (rating): 5 (no visible change)
Determination of Resistance to Dry Heat	AS 2924.2-8: 1998 (EQUI. TO ISO 4586.2-8: 1997)	Effect on surface (rating): 5 (no visible change)
Determination of Resistance to Staining (Procedure A)	AS 2924.2-15: 1998 (EQUI. TO ISO 4586.2-15: 1997)	Effect on surface (rating): 5 (no visible change)
Determination of Resistance to Thermal Shock	AS 2924.2-9: 1999 (EQUI. TO ISO 10545-9: 1994)	Specimens showing defects: Nil

Note: The values quoted above for Quantum Quartz® are average range of values of the different Quartz products tested and should be considered as an indication only. The test results may vary depending on the colours and also the batches of the products.

5. QUANTUM QUARTZ® HYGIENIC CHARACTERISTICS

Quantum Quartz® is certified by the National Health Institute for health harmlessness, the certificate declares the suitability of using Quantum Quartz® for the production of kitchen countertops.

The product is certified by the NSF International organization with this outcome: the product complies with the Standard 51 NSF/ANSI – Food equipment materials, Solid surfaces for Splash zone.

- Content of natural radionuclides (mass activity Ra-226) is less than 120Bq/kg.

Concentration of organic substances in extract into distilled water doesn't exceed these limits:

- Phenol Compounds: 0.05 mg/dm²
- Aromatic Substances formulated as styrene: 0.1 mg/dm²
- Compounds with amino group: 0.05 mg/dm²
- Primary aromatic amines: 0.05 mg/dm²
- Formaldehyde: 0.01 mg/dm²

Concentration of metals in extract of up to 4% acetic acid does not exceed these limits:

- Mercury: 0.01 mg/dm²
- Lead: 0.7 mg/dm²
- Arsenic: 0.01 mg/dm²
- Cadmium: 0.001 mg/dm²
- Antimony: 0.01 mg/dm²
- Barium: 0.2 mg/dm²
- Chromium: 0.01 mg/dm²
- Selenium: 0.01 mg/dm²
- Cobalt: 0.01 mg/dm²

5.1. Surface Flammability and Smoke Development

Quantum Quartz® samples tested comply with surface flammability and smoke development in accordance with ASTM E 84-97a. Average results show:

Flame Spread Index : 10
Smoke Developed : 115

The tests confirmed that the product could be classified as Class A as per the Interior Wall & ceiling finish Category of The National Fire Protection Association Life Safety code 101, Section 6-5.3 (USA).

AS/NZS 1530.3:1999 SIMULTANEOUS DETERMINATION OF IGNITABILITY, FLAME PROPAGATION, HEAT RELEASE & SMOKE RELEASE

Ignitability Index (0-20) 6
Spread of Flame Index (0-10) 4
Heat Evolved Index (0-10) 3
Smoke Developed Index (0-10) 7

6. GENERAL INSTRUCTIONS TO CUSTOMERS

6.1. *General Instructions to Installers*

When taking delivery of Quantum Quartz® sheets, please make sure of the following:

- Check all the slabs for uniformity of colour and granulometry (aggregate distribution) as slabs vary in colour and granulometry.
- Check the slabs for any surface defects including contamination of grains, fine fissures, stains chipping and for warping and thickness variation if any.
- Do not transport slabs horizontally and use proper “A” frames to transport the slabs. Always keep the polished surface covered with plastic film and remove any sharp tools or implement from the vicinity of the slabs to avoid scratches on the polished surface.

If you detect any of the problems after taking delivery of the slabs and prior to cutting, then do not proceed with the processing and return the slabs immediately.

6.2. *Product Identification*

Quantum Quartz sheets carry a product identification label on one side of the slabs giving the details of the product.

Quantum Quartz slabs are also stamped on the reverse side, clearly stating Quantum Quartz brand name, batch number, slab number and production date.

6.3. *Chemicals to Avoid*

Quantum Quartz although resistant to most household chemicals can be permanently damaged by exposure to strong chemicals and solvents that undermine its physical properties including but not limited to the following:

- Acetone
- Thinners
- Products which contain Trichloroethane or Methyl Chloride (paint thinners or strippers)
- High level Alkaline/pH level products.

Use of these products at any stage will void the Quantum Quartz Limited Warranty.

Products recommended for cleaning Quantum Quartz

Always read the cleaning product manufacturer’s instructions and recommendations prior to use.

Firstly, ensure to use a clean micro-fibre cloth to avoid contamination of the Quantum Quartz surface by oils or chemicals from previous cloth use.

- 100% alcohol
- Methylated Spirits
- Isopropyl alcohol
- Quantum Quartz Spray cleaner
- Quantum Quartz Cream cleanser (for stubborn stains – dilute to water consistency)

7. DESIGN AND INSTALLATION GUIDE

7.1. Kitchen / Vanity Cabinets

Prior to installing the bench tops care should be taken to check the cabinets and base units for the following:

- Strong and stable, the cabinets and the sub strata base should be able to withstand Quantum Quartz® bench top of weight in excess of 55 to 60 kgs per square meter.
- Units are fastened to both the wall and each other.
- Check that the cabinets are levelled properly. The cabinets must be plumb, true and flat. Make sure that the level does not vary by a maximum tolerance of 1.6mm over a length of 3 metres.
- Remove any nails, screws or sharp edges from the surfaces where the tops would be placed

7.2. Installation of Benchtops

No one kitchen bench top is the same as the other, however, we have given below some guidelines for installing Quantum Quartz® bench tops. The base supporting the Quantum Quartz® bench tops can be either Complete Perimeter support or Complete underlay support.

- It is not common to have all the walls perfectly square. Please make allowance for such imperfections prior to cutting.
- Benchtops should be placed on a very sound and solid frame or a base which is perfectly flat and true.

i. Complete Perimeter Substrate Support:

- Support the top both front and back with a moisture resistant rail of not less than 90mm wide of 18mm thickness. Then support the back of the slab with 90mm-100mm wide rails spaced at regular interval of approximately 600mm apart as shown below.
- It is important to provide a minimum of 3mm between the edge of the tops and the wall so that any expansion in the wall or top due to temperature variation in the atmosphere could be accommodated. Additional gap of one mm per lineal meter should be provided for bench tops lengths exceeding three meters.
- Apply dabs of flexible glue (silicon) at a regular intervals of not less than 25 cm apart on the back of the top then place the tops gently and level the tops before the glue (silicon) cures.

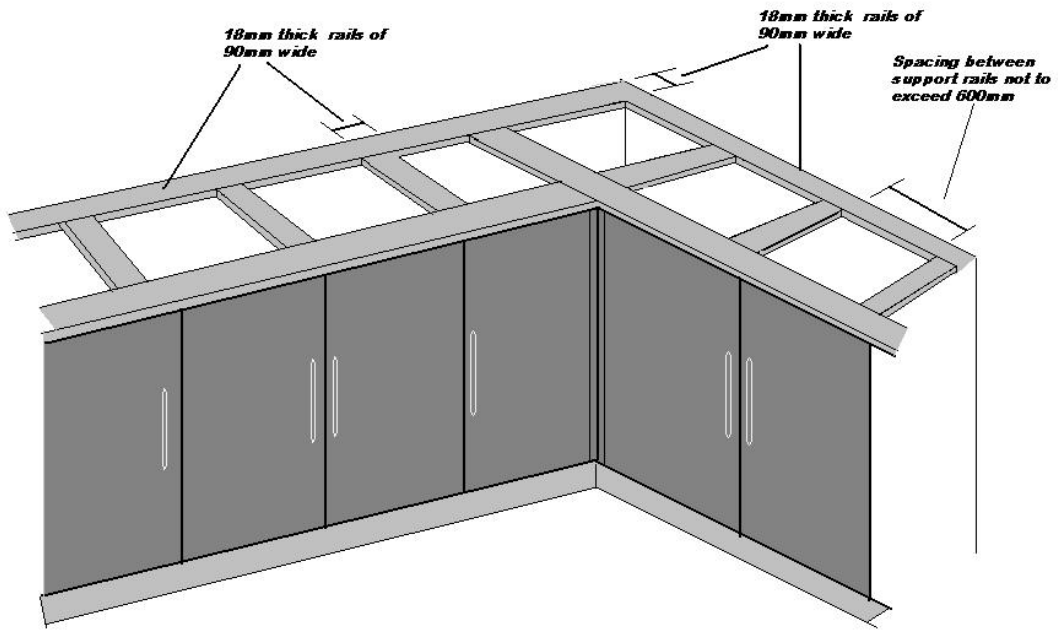

ii) Complete Full substrate support

Alternately the complete surface area of the bench top can be supported over the kitchen cabinets with full width self supporting underlay made up of high moisture resistant MDF or marine plywood of minimum thickness of 18mm.

7.3. Planning and Installation of tops with joints & cut-outs:

- It is important when planning the joints that the cut outs for the sink and cook top etc are not placed less than 15 cm from the joints.
- WK Marble & Granite Pty Ltd does not recommend installing "L" shaped (or other angled) bench tops without a joint at the corner of angle due to various mechanical stresses to be experienced by such tops after installation (example settlement of floors, cabinets etc). Fabricator should use his own discretion when installing "L" shaped (or other angled) bench tops as our warranty does not apply when "L" (or other angled) shaped bench tops are fabricated from one piece of Quantum Quartz® slabs.

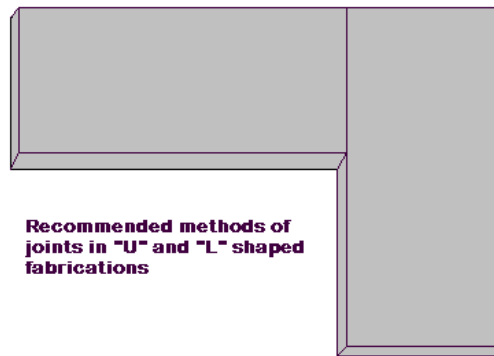

- All the joints in the tops should be well supported underneath.
- All the joints should be properly cleaned with acetone or denatured spirit to get rid of all the dust and grime.
- All the sides of the joints should be straight cut as no to alter the normal thickness and grooved or slotted in the middle so that the glue joining the tops will be well distributed for good adhesion.
- Apply the flexible glue to the joints and also for joining the frame to the bench tops.
- Check that the tops are well aligned both along the joints and also along the front and check that the tops are levelled properly and plumb and true. Use paper masking tape at the joints so that the glue applied to the joints does not move to the polished face.
- Ensure that the joints are perfect and then place clamps at the joints until the adhesive sets properly.
- Once the joints properly set, remove the masking tape and clean off any excess adhesive and also the contact surface with acetone or denatured spirit.
- Do not use any mechanical fasteners like screws and nails to Quantum Quartz®.
- Any modification, alteration to the surface of the products of Quantum Quartz® (e.g. cutting & grooving the surface including manufacture of drain boards etc) is not recommended.

If you are planning to cut the cut outs at the site of installation, it is most essential that the operation is done in an area where you can use wet tools. Never attempt to cut the sink cut outs and cook top cut outs on the top of cabinets with dry cutting tools.

All the cut outs should be cut using only wet cutting tools to avoid generating excess heat to the tops and the corners. The radius of the corner should be around 15mm. When cut outs are planned allow extra 3mm between the appliance edges and the top cut out sides. This is essential to accommodate any expansion that may develop in the top due to temperature changes of the atmosphere.

Internal corners of the cut-outs should be rounded. Prior to cutting cut-outs, drill the corners with a minimum drill hole of 30mm.

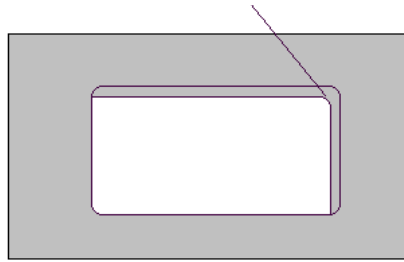

Planning Cut-Outs

- All care should be taken when installing appliances like cook top and sink etc. Read the instruction manual that was supplied along with the appliance prior to commencing installing the appliances. Make sure that all the brackets and supporting nuts are with the pack.
- Care should be taken when joining the tops above any heat generating appliances (e.g. Under bench oven), avoid joints above such heat generating appliances. The warranty becomes null and void if any joints are placed above such appliances.
- Centre all the appliances in the cut out and make sure that you allow minimum of 3mm space between the inside edges of the appliance and the cut out walls.

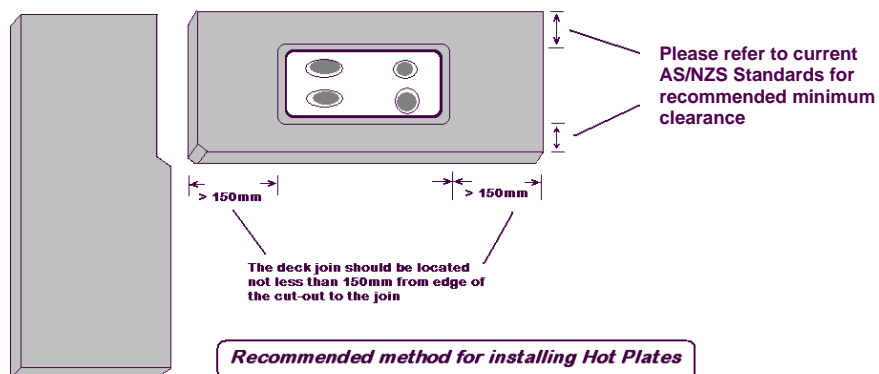

- Position all the appliances in place and make sure that the seals provided with the appliances are properly placed prior to tightening the fasteners to keep the appliances in place. All the fasteners should be only fingering tight never use force in tightening the fasteners.
- Any appliances weighing more than 5kg should be adequately supported by the cabinet frames.

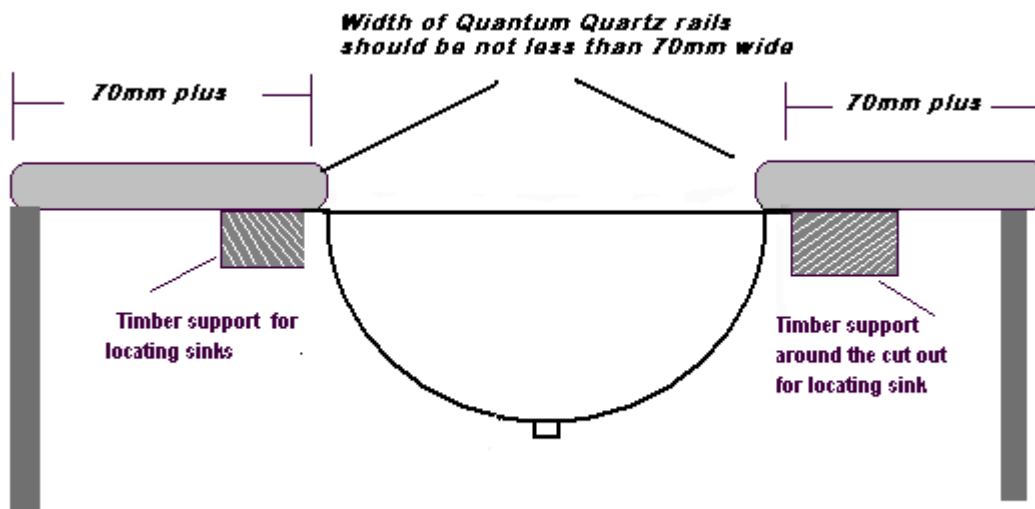

Installation of under the counter sinks

- All the joints between countertop and the appliance edges can be sealed with a high quality transparent flexible sealant. Clean any excess sealant immediately.

7.4 . Installing Dishwashers

- Uneven thermal distribution over part of the bench top may occur in areas above dishwashers, ovens, or other heating appliances such as hot water plumbing systems which may cause the top to crack. To avoid this all the hot water plumbing should be thermally insulated, it is a good practice to make the tap holes slightly oversized so that the hot plumbing system is not in direct contact with the product, and when installing dishwasher or oven, it is essential to fit a 18mm thick moisture resistant board or other suitable insulation above the appliance in the cabinet.

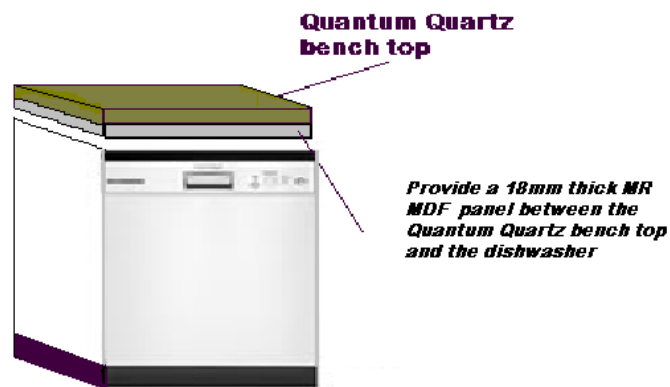

Dishwasher installation

7.5. Overhang and Supporting Brackets

All overhangs provided for the breakfast bar or any top should be properly supported with brackets. Rule of thumb is that any overhang exceeding 300mm shall require 10mm thick, 70mm wide steel bar placed underneath the top or brackets spaced @ 600mm centres. For aesthetic purposes the brackets can be evenly spaced allowing for extra brackets in this case. (See conditions to consider)

All surfaces without direct carcass support underneath are classified as overhangs.

The overhang dimension should be determined by a professional: Technical information can be referred to in this Product Manual, Section 4.4

The dimension of the overhang is governed by certain conditions.

Conditions to consider

1. All overhangs subjected to any loads should be supported with additional supports, regardless of overhang dimension.
2. Overhangs with 40mm lamination i.e. 20mm benchtop with 20mm exposed polish face laminated underneath back to back require minimum 70mm overlap over the carcass.

Recommendations

20mm slabs

<300mm overhang	NO additional support (see condition 1)
300-500mm overhang	support brackets @ 600mm centres or 70x10mm steel bar as per drawing
>500mm overhang	Support posts, panels or columns

30mm slabs

<400mm overhang	NO additional support (see condition 1)
400-600mm overhang	support brackets @ 600mm centres or 70x10mm steel bar as per drawing
>600mm overhang	Support posts, panels or columns

All the overhangs provided for the breakfast bar or any top should be properly supported with brackets. Rule of thumb is that any overhang exceeding 300mm shall require 10mm thick 70mm wide steel bar placed underneath the top.

If the overhang is less than 400mm then the general practice is to provide a support base made up of timber and the brackets placed approximately 500mm apart. All overhangs exceeding 400mm should be supported with proper metal legs. The brackets should be fastened to a backer plate, which is secured with the cabinet with screws.

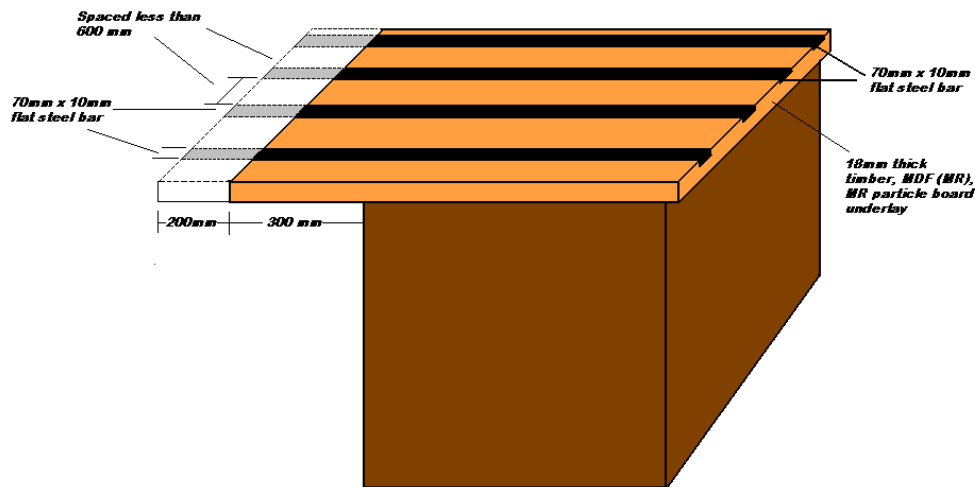

Breakfast bars - support details for overhang exceeding 300mm

7.6. *Installation of Splashback*

Quantum Quartz® can be used for splashback applications in wet areas, behind the wash basins/sinks and behind cook tops. However, when installing splashbacks behind gas cook tops and heat generating appliances, it is important that the Installer and Kitchen Designer must refer to and follow:

- Gas installations require a distance of 200mm from the periphery of the nearest gas burner to any vertical combustible surface. This includes all brands of engineered stone.
- Refer to The Australian & New Zealand Standards AS/NZS 5601.1:2013 Gas Installations for further information.
- AS/NZS 4386.2-1996 Domestic Kitchen Assemblies – Installation.
- Cooktop and appliance manufacturers specific installation guidelines.

The installer must also ensure that the following general guidelines are strictly followed:

- Make sure that the walls are vertical and free from dirt and grime; if so clean the entire surface.
- It is not advisable to install splash backs on gyprock boards and any paper lined gypsum product.
- A fibre cement sheet is recommended, the splash back pieces should be thoroughly cleaned on the back and on the top and place it in the area to be installed and check whether the pieces fit properly.
- After the pieces of cladding satisfactorily fit, then clean the surface of contacts with acetone or denatured spirits and apply dabs of transparent two part epoxy glue to both the surfaces of the contact and place the cladding. It is not advisable to use grout between the cladding and the counter top. Use a flexible silicon to fill the gap between the bench top and the splash backs
- “L” shapes should not be fabricated in one solid piece as this does not allow for movement due to thermal expansion.
- Cut-outs for items such as power points should be core drilled to produce radius internal corners. Cross cutting should be avoided at all times.

7.7. *Cladding Walls*

Quantum Quartz® can be used for all internal cladding of walls and vertical applications. The installation of vertical panels varies from location to location. When designing and installing vertical panels and cladding, it is necessary to take the mass of the product into account and the services of an experienced structural engineer should be sought during the designing and installation phases.

7.8. *Installation of Tiles*

Quantum Quartz® slab and tiles selected for wall / floor applications is an excellent choice that offers the flexibility and visual impact not previously available in the market place. However, as with any tile application it is important to follow the correct fixing methods suitable for the specific applications.

There are no established Australian standards for adhesive fixing of engineered stone tiles, installers in Australia tend to fix the engineered tiles similar to fixing ceramic tiles using adhesives meant for ceramic tiles. Such practices lead to failures in installation.

Tiling systems vary from location to location and may be installed in a number of ways. It is important

for installers to take in to consideration, the following characteristics of the materials that make up the different layers of the tile system and understand how they interact with each other if the complete system has to perform successfully.

- Differential movement
- Structural deflections
- Foundation movements
- Thermal movements
- Moisture movements
- Dimensional stability

Most importantly the thermal movement (expansion and shrinking) of engineered tiles should be taken in to consideration when designing a tile system as the engineered stones have a much higher linear thermal expansion when compared to natural stones and ceramic tiles.

Moisture movements both permanent and reversible changes may occur due to moisture content of the tiling system. Engineered stones have known to possess appreciable reversible moisture movement.

Dimensional stability: This refers to ability of an engineered stone tile to resist curling or warping when exposed to water contained in the adhesives. When the tile surface absorbs moisture the surface of the wet side expands more than the dry side with the result the tiles tend to warp.

The adhesive manufacturers Mapei have vast experience in the installation of the Tiling system using Engineered Stones. Accordingly, we strongly recommend that the installer should consult the manufacturer and seek their advice prior to installation of Quantum Quartz® slab and tiles.

The link to their website is: **Mapei (Australia)**

<http://www.mapei.com>

Quantum Quartz® does not accept any responsibility nor does recommend a particular method of installation, it is the responsibility of the installer / buyer to design the tiling system based on the advice obtained from the engineered tile adhesive manufactures.

7.9. Installation of Kitchen Sinks & Cooktops

Cracks have been known to occur in the narrow strips of bench tops of Quantum Quartz® in front and back of the kitchen sinks and cook tops.

The reasons for the development of cracks are due to several factors.

Stainless steel and fibreglass sinks come in a variety of sizes and shapes. There are several variables associated in the installation of such sinks above or underneath the bench tops:

- the thermal expansion of the units
- fully laden weight of the sinks
- fastening & fitment of the support brackets
- the gauge of the stainless steel
- the type & amount of glue used
- insufficient thermal insulation in the installation of cook tops
- ground movement etc

It is not practical for Quantum Quartz to oversee whether all the parameters have been met by the installer at the time of installation of such equipment/s. Therefore Quantum Quartz will not entertain any claims arising out of cracks developed in the peripheral area of cook tops and sinks and are not covered under 10 Year Limited manufacturers Warranty.

7.10. Installation of Return Side Panel

Cracks developing in the side/return support of Quantum Quartz panel can be avoided provided the panels are glued only to the cabinet. Gluing the Quantum Quartz panel to cabinet and to both floor (in particular to wooden floor which is prone to warping and movement) and walls should be avoided

completely. Gluing the panel to cabinet, floor and walls result in preventing the Quantum Quartz panel to expand or shrink freely thus causing the panel to develop cracks.

Quantum Quartz Warranty does not cover such cracks developed due to non-conformity of approved installation procedures.

7.11. Edge Profile Details

There are numerous edge profiles that can be used to design the edges of Quantum Quartz bench tops. These edges can be designed using 20mm or 30mm slabs or creating 40mm edges by laminating two pieces of 20mm slabs.

Though it is feasible to produce many types of edges the most practical and safest way to design an edge should be a well rounded one with a minimum of 3mm profiled radius or more, the larger the radius the better results in a longer life & general the long life and overall performance of the edge of the bench top. Designing a sharp edge should be completely avoided both from the safety point of view and also to prevent the chipping away of edges.

In addition to designing all visible edges with a minimum of 3mm radius profiles, all the cut edges should be bevelled or chamfered with a minimum of 2mm profile at an angle of 45 degrees. This will prevent accidental damage to edges.

It should be noted that Quantum Quartz Limited Warranty does not cover where the exposed edges have a square edge profile.

The following diagrams show the correct and preferred edge profile design.

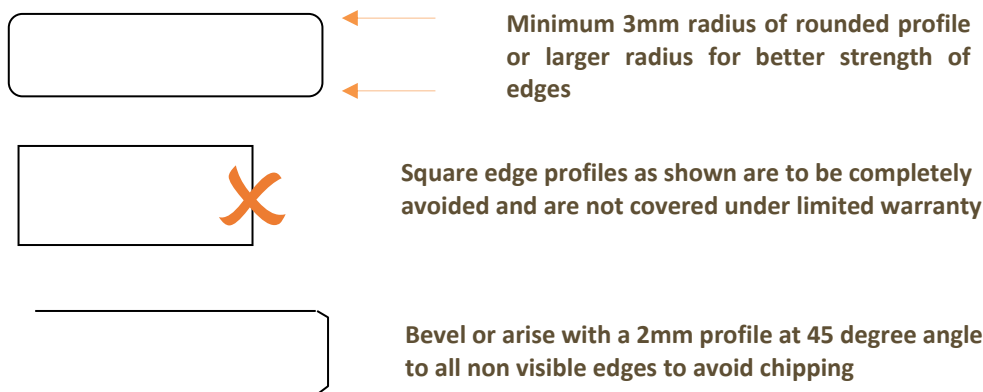

Calacutta Primo Quartz (as with all Natural Quartz colours) is produced using advanced techniques & during these processes the vein is pressed along with the slab as a whole.

There is no control of the outcome on the rear face of the slab. The priority is to ensure the best possible look & clarity is on the front face of the slab.

All slabs should be checked prior to cutting & aligned for best possible fit.

Our recommendation is to use a mitred profile to the edge of the bench top to ensure continuous flow of the vein detail. The apron should be cut adjacent to the edge of the bench top piece to match as close as possible.

7.12. Viewing and inspecting distances

Generally, variations in the surface colour, finish and texture of walls, ceilings, floors and roofs, and variation in glass and similar transparent materials are to be viewed where possible from a normal viewing position. A normal viewing position is looking from a distance of 1.5m or greater (600mm for appliances and fixtures) with the surface or material being illuminated by 'non-critical light'. 'Non-critical light' means the light that strikes the surface is diffused and is not glanced or parallel to that surface.

Slight variations in the colour and finish of materials do not constitute as a defect.

NORMAL VIEWING POSITIONS

Reference: HIA Guide to Kitchen & Bathroom Construction / Australian Standards

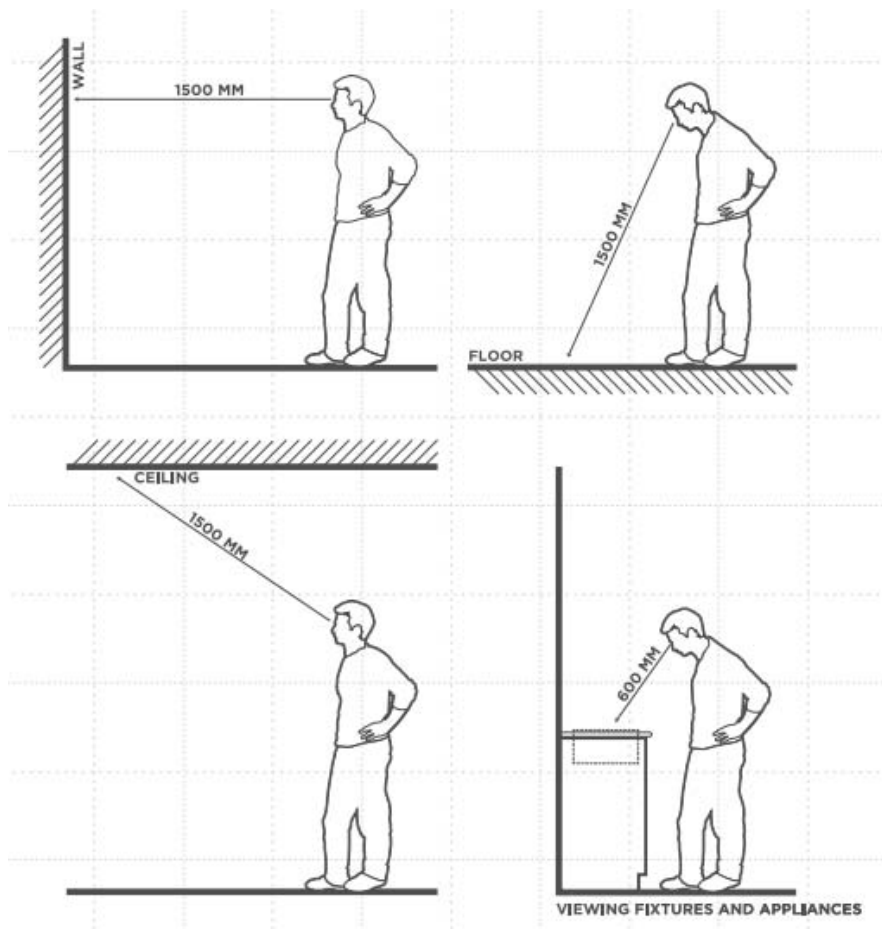

SAFETY DATA SHEET

1. IDENTIFICATION OF THE MATERIAL AND SUPPLIER

1.1 Product identifier

Product name QUANTUM QUARTZ
Synonyms QUANTUM QUARTZ JUMBO • QUANTUM QUARTZ XL • VICOSTONE QUARTZ SURFACES

1.2 Uses and uses advised against

Uses DECORATIVE STONE • ENGINEERED STONE

1.3 Details of the supplier of the product

Supplier name QUANTUM QUARTZ
Address 129 Fairford Rd, Padstow, NSW, 2211, AUSTRALIA
Telephone (02) 9772 9888
Fax (02) 9772 9889
Email technical@wk.com.au
Website <http://www.wk.com.au>

1.4 Emergency telephone numbers

Emergency (02) 9772 9888

2. HAZARDS IDENTIFICATION

2.1 Classification of the substance or mixture

CLASSIFIED AS HAZARDOUS ACCORDING TO SAFE WORK AUSTRALIA CRITERIA

Physical Hazards

Not classified as a Physical Hazard

Health Hazards

Carcinogenicity: Category 1A
Specific Target Organ Toxicity (Repeated Exposure): Category 1

Environmental Hazards

Not classified as an Environmental Hazard

2.2 GHS Label elements

Signal word DANGER

Pictograms



Hazard statements

H350i May cause cancer by inhalation.
H372 Causes damage to organs through prolonged or repeated exposure.

PRODUCT NAME QUANTUM QUARTZ

Prevention statements

P201	Obtain special instructions before use.
P202	Do not handle until all safety precautions have been read and understood.
P260	Do not breathe dust/fume/gas/mist/vapours/spray.
P264	Wash thoroughly after handling.
P270	Do not eat, drink or smoke when using this product.
P281	Use personal protective equipment as required.

Response statements

P308 + P313	IF exposed or concerned: Get medical advice/ attention.
-------------	---

Storage statements

P405	Store locked up.
------	------------------

Disposal statements

P501	Dispose of contents/container in accordance with relevant regulations.
------	--

2.3 Other hazards

The solid product as supplied is classified as non-hazardous under normal conditions and does not present an inhalation, ingestion, skin, or eye hazard. However, dust created when the product is cut, grinded and machined may contain crystalline silica some of which may be respirable (particles small enough to go into deep parts of the lung when breathed in).

3. COMPOSITION/ INFORMATION ON INGREDIENTS

3.1 Substances / Mixtures

Ingredient	CAS Number	EC Number	Content
QUARTZ (CRYSTALLINE SILICA)	14808-60-7	238-878-4	>88%
ADDITIVE(S)	-	-	Remainder
UNSATURATED POLYESTER RESIN	-	-	<10%

Ingredient Notes Additives include resins and trace minerals including Al₂O₃, Fe₂O₃, TiO₂, CaO, MgO, Na₂O, K₂O, etc.

4. FIRST AID MEASURES

4.1 Description of first aid measures

Eye	(Dust exposure) Flush gently with running water, irrigating under eyelids. Seek medical attention if irritation develops.
Inhalation	(Dust exposure) If inhaled remove from contaminated area. Apply artificial respiration if not breathing.
Skin	(Dust exposure) Gently flush affected areas with water. Seek medical attention if irritation develops.
Ingestion	Due to product form and application, ingestion is considered unlikely.
First aid facilities	Eye wash facilities and safety shower should be available, particularly when dust is generated.

4.2 Most important symptoms and effects, both acute and delayed

This material may only present a hazard if cut, sanded or drilled with dust generation. Chronic exposure to dust may result in lung fibrosis (silicosis).

4.3 Immediate medical attention and special treatment needed

Treat symptomatically.

5. FIRE FIGHTING MEASURES

5.1 Extinguishing media

Dry agent, carbon dioxide, foam or water fog. Prevent contamination of drains or waterways.

5.2 Special hazards arising from the substance or mixture

Combustible. May evolve toxic gases if strongly heated.

5.3 Advice for firefighters

Evacuate area and contact emergency services. Toxic gases may be evolved in a fire situation. Remain upwind and notify those downwind of hazard. Wear full protective equipment including Self Contained Breathing Apparatus (SCBA) when combating fire. Use waterfog to cool intact containers and nearby storage areas.

5.4 Hazchem code

None allocated.

6. ACCIDENTAL RELEASE MEASURES

6.1 Personal precautions, protective equipment and emergency procedures

Wear Personal Protective Equipment (PPE) as detailed in section 8 of the SDS.

6.2 Environmental precautions

Prevent product from entering drains and waterways.

6.3 Methods of cleaning up

Collect and reuse where possible.

6.4 Reference to other sections

See Sections 8 and 13 for exposure controls and disposal.

7. HANDLING AND STORAGE

7.1 Precautions for safe handling

Before use carefully read the product label. Use of safe work practices are recommended to avoid eye or skin contact and inhalation. Observe good personal hygiene, including washing hands before eating. Prohibit eating, drinking and smoking in contaminated areas.

7.2 Conditions for safe storage, including any incompatibilities

Ensure material is adequately labelled and protected from physical damage. Avoid generating dust.

7.3 Specific end uses

No information provided.

8. EXPOSURE CONTROLS / PERSONAL PROTECTION

8.1 Control parameters

Exposure standards *refer local state regulators

Ingredient	Reference	TWA		STEL	
		ppm	mg/m ³	ppm	mg/m ³
Quartz (respirable dust)	SWA [AUS]	--	0.1	--	--
Quartz (respirable dust)	SWA [Proposed]	--	0.05*	--	--

Biological limits

No biological limit values have been entered for this product.

8.2 Exposure controls

Engineering controls Avoid inhalation. Use in well ventilated areas. Where an inhalation risk exists, mechanical extraction ventilation is recommended. Wet cut, polish, sand, grind or drill only. Maintain dust levels below the recommended exposure standard.

PPE

- Eye / Face** If cutting or sanding with potential for dust generation, wear dust-proof goggles.
- Hands** Wear PVC, rubber or cotton gloves when handling material to prevent skin contact.
- Body** Not required under normal conditions of use.
- Respiratory** All efforts should be made to avoid uncontrolled dry cutting, sanding, polishing, grinding or drilling, but if alterations are unavoidable use a half face (negative pressure) with minimum P1 or P2 particulate respirator & tools that have water suppression & on tool dust extraction with H class rating. Consultation with relevant State Worksafe offices for further details is recommended.



9. PHYSICAL AND CHEMICAL PROPERTIES

9.1 Information on basic physical and chemical properties

Appearance	MULTI-COLOURED STONE
Odour	ODOURLESS
Flammability	COMBUSTIBLE
Flash point	450°C to 490°C
Boiling point	NOT AVAILABLE
Melting point	NOT AVAILABLE
Evaporation rate	NOT AVAILABLE
pH	NOT AVAILABLE
Vapour density	NOT AVAILABLE
Specific gravity	2.0 to 2.5
Solubility (water)	INSOLUBLE
Vapour pressure	NOT AVAILABLE
Upper explosion limit	NOT RELEVANT
Lower explosion limit	NOT RELEVANT
Partition coefficient	NOT AVAILABLE
Autoignition temperature	> 450°C
Decomposition temperature	NOT AVAILABLE
Viscosity	NOT AVAILABLE
Explosive properties	NOT EXPLOSIVE
Oxidising properties	NON OXIDISING
Odour threshold	NOT AVAILABLE

10. STABILITY AND REACTIVITY

10.1 Reactivity

Carefully review all information provided in sections 10.2 to 10.6.

10.2 Chemical stability

Stable under recommended conditions of storage.

10.3 Possibility of hazardous reactions

Polymerization is not expected to occur.

10.4 Conditions to avoid

No known conditions to avoid.

10.5 Incompatible materials

Incompatible with strong acids (e.g. hydrochloric acid).

10.6 Hazardous decomposition products

This material will not decompose to form hazardous products.

11. TOXICOLOGICAL INFORMATION

11.1 Information on toxicological effects

Acute toxicity	This product is expected to be of low acute toxicity. Under normal conditions of use, adverse health effects are not anticipated.
Skin	Not classified as a skin irritant. However, dust formed during operations such as incise, grinding and machining may result in mild irritation, rash and dermatitis.
Eye	Not classified as a skin irritant. However, dust formed during operations such as incise, grinding and machining may result in mild irritation, lacrimation and redness.
Sensitisation	Not classified as causing skin or respiratory sensitisation.
Mutagenicity	Not classified as a mutagen.
Carcinogenicity	Adverse health effects, usually associated with long term exposure to high respirable crystalline silica quartz dust levels are not anticipated due to product form. This product may only present a hazard if rocks are cut or drilled with dust generation. Respirable crystalline silica quartz is classified as carcinogenic to humans (IARC Group 1).
Reproductive	Insufficient data available to classify as a reproductive toxin.
STOT - single	Dust can be generated during cutting of the product. Dusts are mechanical irritants that may cause throat

PRODUCT NAME QUANTUM QUARTZ

exposure	irritation. Not classified as causing organ damage from single exposure.
STOT - repeated exposure	Adverse health effects, usually associated with long term exposure to high respirable crystalline silica quartz dust levels are not anticipated due to the product form. This product may present a hazard if cut or drilled with dust generation. CAUTION: Repeated exposure to dust may cause lung fibrosis (silicosis).
Aspiration	Not applicable for solids.

12. ECOLOGICAL INFORMATION

12.1 Toxicity

This material is not expected to cause harm to animals, plants or fish.

12.2 Persistence and degradability

Product is persistent and non-degradable.

12.3 Bioaccumulative potential

Not expected to bioaccumulate.

12.4 Mobility in soil

A low mobility would be expected in a landfill situation.

12.5 Other adverse effects

The main component/s of this product are not anticipated to cause any adverse effects to plants or animals.

13. DISPOSAL CONSIDERATIONS

13.1 Waste treatment methods

Waste disposal Reuse where possible. Dispose of in accordance with local regulations.

Legislation Dispose of in accordance with relevant local legislation.

14. TRANSPORT INFORMATION

NOT CLASSIFIED AS A DANGEROUS GOOD BY THE CRITERIA OF THE ADG CODE, IMDG OR IATA

	LAND TRANSPORT (ADG)	SEA TRANSPORT (IMDG / IMO)	AIR TRANSPORT (IATA / ICAO)
14.1 UN Number	None allocated.	None allocated.	None allocated.
14.2 Proper Shipping Name	None allocated.	None allocated.	None allocated.
14.3 Transport hazard class	None allocated.	None allocated.	None allocated.
14.4 Packing Group	None allocated.	None allocated.	None allocated.

14.5 Environmental hazards

No information provided.

14.6 Special precautions for user

Hazchem code None allocated.

15. REGULATORY INFORMATION

15.1 Safety, health and environmental regulations/legislation specific for the substance or mixture

Poison schedule A poison schedule number has not been allocated to this product using the criteria in the Standard for the Uniform Scheduling of Medicines and Poisons (SUSMP).

Classifications Safework Australia criteria is based on the Globally Harmonised System (GHS) of Classification and Labelling of Chemicals.

Inventory listings **AUSTRALIA: AICS (Australian Inventory of Chemical Substances)**
All components are listed on AICS, or are exempt.

16. OTHER INFORMATION

Additional information

PERSONAL PROTECTIVE EQUIPMENT GUIDELINES:

The recommendation for protective equipment contained within this report is provided as a guide only. Factors such as form of product, method of application, working environment, quantity used, product concentration and the availability of engineering controls should be considered before final selection of personal protective equipment is made.

HEALTH EFFECTS FROM EXPOSURE:

It should be noted that the effects from exposure to this product will depend on several factors including: form of product; frequency and duration of use; quantity used; effectiveness of control measures; protective equipment used and method of application. Given that it is impractical to prepare a report which would encompass all possible scenarios, it is anticipated that users will assess the risks and apply control methods where appropriate.

Abbreviations

ACGIH	American Conference of Governmental Industrial Hygienists
CAS #	Chemical Abstract Service number - used to uniquely identify chemical compounds
CNS	Central Nervous System
EC No.	EC No - European Community Number
EMS	Emergency Schedules (Emergency Procedures for Ships Carrying Dangerous Goods)
GHS	Globally Harmonized System
GTEPG	Group Text Emergency Procedure Guide
IARC	International Agency for Research on Cancer
LC50	Lethal Concentration, 50% / Median Lethal Concentration
LD50	Lethal Dose, 50% / Median Lethal Dose
mg/m ³	Milligrams per Cubic Metre
OEL	Occupational Exposure Limit
pH	relates to hydrogen ion concentration using a scale of 0 (high acidic) to 14 (highly alkaline).
ppm	Parts Per Million
STEL	Short-Term Exposure Limit
STOT-RE	Specific target organ toxicity (repeated exposure)
STOT-SE	Specific target organ toxicity (single exposure)
SUSMP	Standard for the Uniform Scheduling of Medicines and Poisons
SWA	Safe Work Australia
TLV	Threshold Limit Value
TWA	Time Weighted Average

Report status

This document has been compiled by RMT on behalf of the manufacturer, importer or supplier of the product and serves as their Safety Data Sheet ('SDS').

It is based on information concerning the product which has been provided to RMT by the manufacturer, importer or supplier or obtained from third party sources and is believed to represent the current state of knowledge as to the appropriate safety and handling precautions for the product at the time of issue. Further clarification regarding any aspect of the product should be obtained directly from the manufacturer, importer or supplier.

While RMT has taken all due care to include accurate and up-to-date information in this SDS, it does not provide any warranty as to accuracy or completeness. As far as lawfully possible, RMT accepts no liability for any loss, injury or damage (including consequential loss) which may be suffered or incurred by any person as a consequence of their reliance on the information contained in this SDS.

Prepared by

Risk Management Technologies
 5 Ventnor Ave, West Perth
 Western Australia 6005
 Phone: +61 8 9322 1711
 Fax: +61 8 9322 1794
 Email: info@rmt.com.au
 Web: www.rmtglobal.com

[End of SDS]

10 Year Limited Warranty

Warranty Terms & Conditions

Congratulations on your recent purchase of Quantum Quartz...
thank you for choosing us for your project!

Quantum Quartz supplies material to your stonemason in slab format. Your stonemason of choice will cut, polish and install your bench top. All Quantum Quartz material gets checked when it arrives in our warehouse & before it leaves. After it leaves our warehouse, Quantum Quartz has no control with transportation, manufacturing or installation.

Please take the time to read our care and maintenance recommendations. By following the proper installation, care and maintenance of Quantum Quartz you should have many years of enjoyment from our Product.

Listed below are the terms and conditions applicable to Quantum Quartz engineered stone.

What is included in the warranty:

1. Quantum Quartz offers a 10 year limited warranty to the original customer for a period of 10 years from the date of installation.
2. The warranty covers any defects arising from the manufacture of the slab. Subsequent fabrication and installation are not covered in this warranty.
3. The Warranty is limited to a) replacing the material b) refunding the value of the material c) repairing the material. The warranty does not include fabrication and installation of the material.

What is not included in the warranty:

1. Any defect or damage to the Product arising from work done by anyone other than Quantum Quartz.
2. The fabrication and installation of the Product by other parties.
3. The use of the Product as flooring or outdoors (including BBQ areas) or in areas near swimming pools.
4. Changes in colour in different light conditions and discolouration or fading due to exposure to natural or artificial UV, sunlight or silicon (or similar)
5. Any modification or alteration (including the use of sealers or colour enhancers) to the surface of Quantum Quartz.
6. Damage to the Product due to prolonged exposure to chemicals or solvents; such as (but not limited to) acetone, thinners, paint stripper, cleaners that have high alkaline/pH levels
7. Damage by:
 - a. Placing hot pots / pans (including electric fry pans) on the surface
 - b. Applying excessive weight to the surface
8. The 'Pearly Shores' Product has sea shells distributed throughout the material. These shells are susceptible to staining and will react to vinegar, citric acid, fruit juices and other mild acids and detergents. The shells can be abraded, scratched or dislodged if they come in contact with citrus products, chemicals, harder materials or sharp tools. No claims will be accepted if such defects appear after installation.
9. Any defect or damage as a result of the Product not being cleaned in accordance with the Quantum Quartz Care and Maintenance Guide.
10. Variations in colour, pattern or shade of the material against sample material, displayed or illustrated material. Quantum Quartz is made from natural material & some colour variation will occur between batches.
11. Failure of adhesives, caulking materials, damage resulting due to the accessories installed failure due to inadequate support to joints and seams.
12. Failure to follow any procedures, instructions and recommendations given in the Product Manual provided to the fabricators and/or Customers.
13. Damage as a result of sitting, climbing or standing on the Product.
14. Any defect or damage as a result of mishandling or abuse.
15. Bowing less than 1.5mm per 1000mm of material.
16. Cracks are not a material fault. They are not covered in the warranty and are usually a result of:
 - a. Mechanical stress on the material after installation
 - b. Settlement or movement in joinery or house as a whole
 - c. Sitting, standing or climbing on your bench top
 - d. Excessive heat
 - e. Sink or cook top cut out (not covered)
 - f. "L" shaped cut out / improper installation
17. Chipping is not a material fault; it is normally a direct result due to impact to the edge of the surface. Chips are not covered by this warranty.
18. Fireplaces are not covered as a result of variations in design and heat output.
19. The warranty only applies if the Product was installed by a qualified and licensed stonemason.

20. Very infrequent 'greyish' or 'reddish' dots in the 'Galaxy' colours are normal. These dots are the reverse side of a mirror and are an expected result of the manufacturing process. Other very inconsistent small dots are part of the natural quartz used in the manufacturing process and are an accepted part of the material.
21. 'Galaxy' colours may show minor pitting on the surface due to the manufacturing processes of the mirror (glass). This is unavoidable and not considered a fault in the Product. We suggest inspection of slabs prior to purchase or cutting as no claims will be considered relating to pitting in the 'Galaxy' colours.
22. Small infrequent dots may appear in the material. These can be darker or lighter pieces of quartz in relation to the base colour and are not considered a fault of the material. Infrequent small white dots present in Midnight Black for example are particles of Quartz used in the manufacturing process and are accepted as part of the material.
23. On Natural Quartz Collection colours, some black/greyish dots may appear both large or small. There may also be inconsistencies in the veining pattern or background. This is not a defect; the inconsistencies are designed to mirror the look of natural stone.
24. 'Character' colours such as Ash Grey, Portobello, Dolce, Amaretti, and others include sporadic small circles and darker spots. These inclusions are not faults but are added intentionally and add to the unique & inconsistent character of the stone.
25. Concrete Matte is a unique and inconsistent colour. Due to raw material mix used to make this colour and the unique polishing methods you may see small areas/spots of the stone that seem to be slightly more/less polished than others. This effect may be more noticeable when the bench is viewed under intense artificial or natural light. This is not a defect in the stone.
26. Concrete colours Naturale Concrete and Metro Concrete have an uneven finish which may show inconsistent spots, mineral glitter and pits. These features, although sporadic, are part of the 'rough matte' finish production process and are not considered a defect.

Statutory Rights

The limitations on the Warranty set out in this document do not exclude or limit the application of the mandatory conditions or warranties implied by the Trade Practices Act 1974 or any other equivalent or corresponding legislation.

Registering your Warranty

Please register your warranty online at www.wk.com.au. This will enable us to offer you better customer service.

Making a Claim

Please address any claim in writing within 28 days of the occurrence to:

WK Trading Services P/L
 Trading as Quantum Quartz
 129 Fairford Road Padstow NSW 2211
 Tel: +612 9772 9888
 Email: marketing@wk.com.au

Care and Maintenance Guide

Quantum Quartz is an extremely strong material but you should avoid:

- Sitting, standing or climbing on your bench top
- Direct exposure to hot pots, pans or other hot items
- Cutting food directly on the surface
- Knocking, dropping or bumping the Product with heavy items
- Exposure to strong chemicals and solvents

Matte finish products are as durable as our polished range however they are prone to oil marks from 'oily' based products and even our own natural skin. These are not permanent stains however extra care is required in order to maintaining your matte finish product.

Note: all silicon or similar based products may leave a shiny film on the surface, causing a shiny appearance which cannot be removed. This is an unavoidable part of the installation and should be restricted to the necessary (splashback and joint sealing) areas of the benchtop.

Quantum Quartz is extremely low maintenance.

- For every day cleaning use a mild cleaner or **Quantum Quartz Spray Cleaner** and wipe with a soft cloth or sponge. Ensure you remove all cleaner residue with damp cloth or sponge.
- For stubborn stains use **Quantum Quartz Cream Cleanser***
- Quantum Quartz is virtually non-porous and does not require sealing or polishing to maintain its semi-gloss, smooth finish

NOTE: When cleaning with the Quantum Quartz Cream Cleanser, please dilute with water first, then apply with a non-scratch scourer or soft cloth.

When unsure test the Cream Cleanser on a small piece of your bench that is out of view.

Quantum Quartz is not a full gloss finish, it is a semi-gloss. If your bench top looks too shiny or blotchy please review your cleaning methods.



TO VIEW THE QUANTUM QUARTZ CARE & MAINTENANCE VIDEO VISIT www.wk.com.au

*Quantum Quartz Cream Cleanser is available at select kitchen companies and fabricators as well as online at wk.com.au

This document supersedes all previous versions and is subject to change without notice

ABN 25 634 557 145